

1500B单泵爆炸图

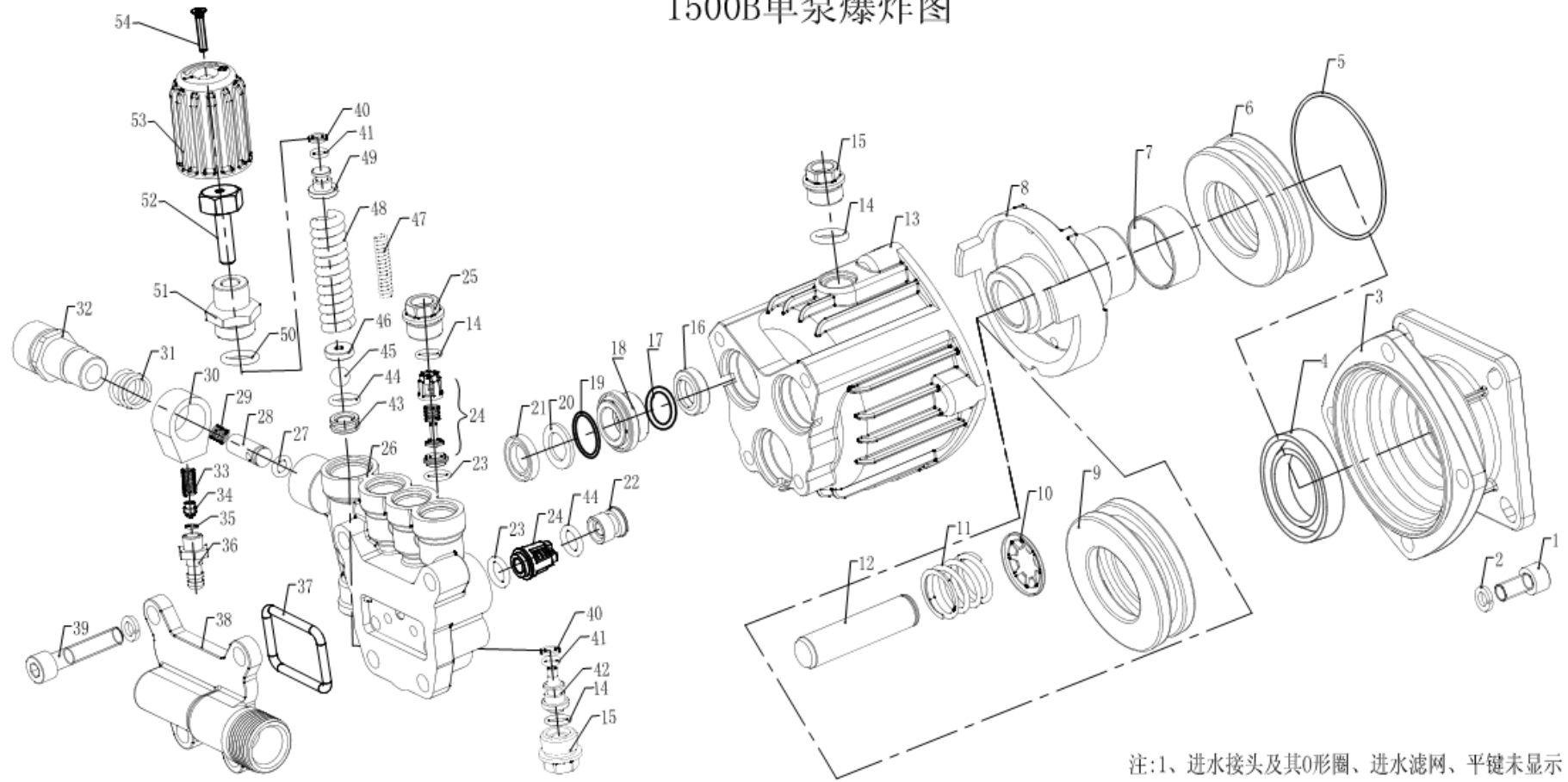

注:1、进水接头及其O形圈、进水滤网、平键未显示

No	Name&Size	qty	No	Name&Size	qty	No	Name&Size	qty	No	Name&Size	qty	No	Name&Size	qty
1	Screw	4	12	Plunger	3	23	O ring9.6*2	6	34	Self priming valve	1	45	Steel ball	1
2	Spring washer	8	13	Crankcase	1	24	Checking valve part	6	35	O ring 3*1.5	1	46	Pressure adjusting spring seat down	1
3	Flange	1	14	O ring 12.5*1.8	6	25	Valve cage	3	36	Suction connector	1	47	Pressure adjusting spring (inside)	1
4	Oil seal	1	15	Plunger plug	3	26	Cylinder block	1	37	Inlet connector seal	1	48	Pressure adjusting spring (outside)	1
5	O ring 80*1.8	1	16	Oil seal	3	27	O ring4*2.4	1	38	Inlet connector	1	49	Pressure adjusting spring seat up	1
6	Bearing	1	17	O ring 14*1.8	3	28	Spindle	1	39	Screw	4	50	O ring16*2	1
7	Axle sleeve	1	18	Backup ring	3	29	Outlet sping	1	40	Backup ring	2	51	Valve body	1
8	Swash plate	1	19	O ring20*1.8	3	30	Suction adaptor	1	41	O ring4.5*2	2	52	Bolt	1
9	Bearing	1	20	Water seal washer	3	31	O ring13.2*2	3	42	Pressure adjusting spindle	1	53	Pressure adjusting cap	1
10	Spring cover	3	21	Water seal	3	32	Outlet adaptor	1	43	Seat	1	54	Screw	1
11	Plunger sping	3	22	Pressure cap	3	33	Suction spring	1	44	O ring9.4*1.9	4			